

The kSA BandiT is a non-contact, non-invasive, real-time, wafer and film temperature monitor used for process monitoring and control during thin-film deposition and thermal processing. Using the temperature-dependent optical absorption edge inherent in semiconductor materials, kSA BandiT provides temperature monitoring in applications where pyrometers cannot, including substrates that are transparent in the IR (such as GaN, SiC, ZnO, and SrTiO₃), and at low temperatures (such as GaAs, InP, and Si). Unlike conventional pyrometry, BandiT's band edge temperature measurement technique is insensitive to changing viewport transmission, stray light, and signal contribution from substrate or source heaters. The kSA BandiT offers the following real-time analysis capabilities:

- Semiconductor band edge temperature
- Blackbody temperature (based on emission profile)
- Broadband pyrometry temperature w/user-programmable wavelength range
- Film thickness
- Film growth rate
- Surface roughness



kSA BandiT Measurement Technologies

Band Edge Temperature: BandiT measures a semiconductor’s optical absorption edge shift with temperature (i.e. band gap temperature dependence) and uses kSA-generated calibration files to determine the temperature.

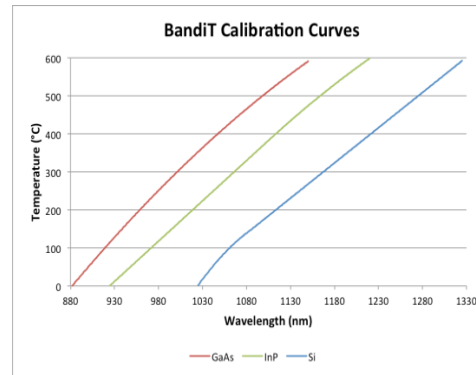
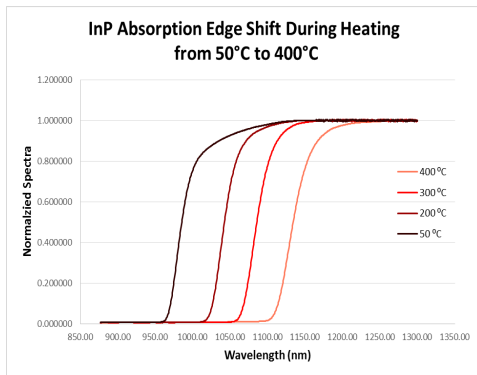

Blackbody Temperature: The intensity of spectral radiation emitted by a sample is fit to Planck’s equation in real-time to determine the temperature. High temperature blackbody calibration ensures run-to-run repeatability and unmatched resolution. kSA BandiT blackbody technology is compatible with semiconductor substrates ($E_g < 1.4$ eV), ceramics, and metal films.

Broadband Pyrometry: Measures the integrated blackbody radiation intensity of a sample over a user-programmable wavelength range to determine temperature. This allows the user greater flexibility and sensitivity than offered by standard NIR pyrometers. Pyrometry measurements may be calibrated via BandiT’s band edge or blackbody temperature measurement, or other user defined methods.

Film Thickness and Growth Rate: The thickness and growth rate of a film may be determined in real-time through analysis of extrema positions in the below-gap interference spectra, or by the temporal oscillations at a single or multiple wavelengths during deposition.

Surface Roughness: By monitoring changes in the above gap diffuse reflectivity signal vs. wavelength, kSA BandiT provides a relative measurement of surface roughness.

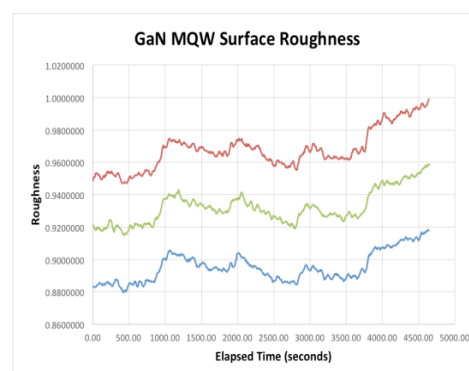
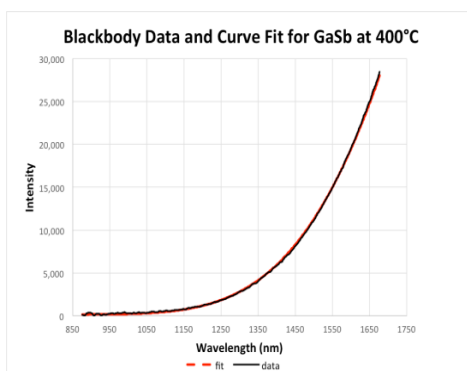

kSA BandiT Models

Models	Description
<p>B-NIR-MBE-1670</p> <p><i>Spectrometer: 870-1670 nm, 128 element InGaAs array, integration time: 10 μs - 5s.</i></p>	<ul style="list-style-type: none"> Measures band edge substrate temperature (ideal for GaAs, InP, and Si) <ul style="list-style-type: none"> Band Edge temperature range: RT - 750°C (SI GaAs)¹ Measure blackbody temperature for substrates with $E_g < 1.4$ eV (includes metals and materials such as GaSb, InAs, and Ge) <ul style="list-style-type: none"> Blackbody temperature range: ≥ 350 °C¹ Measures temperature via broadband, user-programmable pyrometry Measures real-time growth rate, film thickness and surface roughness <ul style="list-style-type: none"> Film thickness accuracy: ± 1 nm after 1200 nm of epilayer²
<p>B-NIR-MBE-1400</p> <p><i>Spectrometer: 870-1400 nm, 128 element InGaAs array, integration time: 10 μs - 5s.</i></p>	<ul style="list-style-type: none"> Measures band edge substrate temperature (ideal for GaAs, InP, and Si), used mainly for applications where excess blackbody radiation may decrease tool performance, such as in large production chambers. <ul style="list-style-type: none"> Band Edge temperature range: RT - 750 °C (SI GaAs)¹ Measure blackbody temperature for substrates with $E_g < 1.4$ eV (includes metals and materials such as GaSb, InAs, and Ge) <ul style="list-style-type: none"> Less ideal than 870-1670 nm spectrometer due to reduced spectral range; specifications vary significantly depending on substrate material. Measures temperature via broadband, user-programmable pyrometry Measures real-time growth rate, film thickness and surface roughness <ul style="list-style-type: none"> Film thickness accuracy: ± 1 nm after 1200 nm of epilayer²
<p>B-VIS-MBE-1100</p> <p><i>Spectrometer: 600-1100 nm, 512 element cooled Si CCD, integration time: 4ms - 20s.</i></p>	<ul style="list-style-type: none"> Measures band edge substrate temperature (ideal for CdTe, CdZnTe (CZT), ZnSe and ZnTe) <ul style="list-style-type: none"> Temperature range: RT-350°C (for $Cd_{0.96}Zn_{0.04}T$)¹ Measures real-time growth rate, film thickness and surface roughness <ul style="list-style-type: none"> Film thickness accuracy: ± 1 nm after 1200 nm of epilayer²
<p>B-VIS-MBE-600</p> <p><i>Spectrometer: 350-600 nm, 512 element cooled Si CCD, integration time: 4ms - 20s.</i></p>	<ul style="list-style-type: none"> Measures band edge substrate temperature (ideal for SiC, GaN, GaN/ Sapphire, ZnO, and SrTiO₃) <ul style="list-style-type: none"> Temperature range: 300 - 1200 °C (for GaN substrates or GaN (>3 μm)/sapphire templates)¹ Measures real-time growth rate, film thickness and surface roughness <ul style="list-style-type: none"> Film thickness accuracy: ± 1 nm after 1200 nm of epilayer²

Please note that most specifications are material system and chamber dependent.

¹The BandiT temperature range depends on substrate material, dopant level, thickness, polish, and mounting, as well as the measurement geometry and the epi-layer material being grown. For other materials and structures, please contact k-Space for the appropriate BandiT specifications.

²Thickness measurement generally requires at least 1.2 μm of film grown on a layer of different index of refraction, but can then be used to monitor very small (~ 1 nm) incremental changes. Growth rate can also be measured via temporal oscillations at user-selectable wavelengths. For other materials and structures, please contact k-Space for the appropriate specifications.



kSA BandiT System Specifications

Each BandiT model comes equipped with an integrated spectrometer and all control electronics, packaged in a standard 3U rack-mounted unit, a standard BandiT Light Source (B-LS), a standard BandiT Detector (B-TRD), required optics, cables, and fibers for the model selected, standard kSA BandiT software and software license, and an additional software license for post-acquisition analysis. For more details, see the specification table listed below.

<i>Models</i>	B-NIR-MBE-1670	B-NIR-MBE-1400	B-VIS-MBE-1100	B-VIS-MBE-600
Detector	B-TRD	B-TRD	B-TRD	B-TRD
Detector Mounting¹	2.75" CF and 4.5" CF	2.75" CF and 4.5" CF	2.75" CF and 4.5" CF	2.75" CF and 4.5" CF
Detector Lens	1" diam. (B-LENS-NIR)	1" diam. (B-LENS-NIR)	1" diam. (B-LENS-NIR)	1" diam. (B-LENS-VIS)
Detector Collection Area	~ 4-6 mm diameter for viewport to sample distance of 400-760mm	~ 4-6 mm diameter for viewport to sample distance of 400-760mm	~ 4-6 mm diameter for viewport to sample distance of 400-760mm	~ 4-6 mm diameter for viewport to sample distance of 400-760mm
Detector Fiber	LOH, single core, 10 m, SMA (B-FIB-NIR)	LOH, single core, 10 m, SMA (B-FIB-NIR)	LOH, single core, 10 m, SMA (B-FIB-NIR)	HOH, single core, 10 m, SMA (B-FIB-VIS)
Light Source	B-LS	B-LS	B-LS	B-LS
Light Source Mounting¹	2.75" CF and 4.5" CF	2.75" CF and 4.5" CF	2.75" CF and 4.5" CF	2.75" CF and 4.5" CF
Light Bulb	Gold coated Tungsten Halogen (EKE-NIR)	Gold coated Tungsten Halogen (EKE-NIR)	Gold coated Tungsten Halogen (EKE-NIR)	Tungsten Halogen (EKE-VIS)
Light Source Power Cable	10 m (BCC30)	10 m (BCC30)	10 m (BCC30)	10 m (BCC30)
Spectrometer	870-1670 nm, 128 element InGaAs array, Integration time: 10 μ s - 5 s.	870-1400 nm, 128 element InGaAs array, Integration time: 10 μ s - 5 s.	600-1100 nm, 512 element Si CCD, cooled, Integration time: 4 ms - 20 s.	350-600 nm, 512 element Si CCD, cooled, Integration time: 4 ms - 20 s.
Control cable	USB cable from BandiT Rack to control computer, 5 m			
Rack Power Cable	1.5 m			
Power	120/240 VAC			
Alignment Laser	655 nm, 3 mW, SMA connector on back of the BandiT rack			
Home Pulse or Trigger Input	BNC connector on BandiT Rack, accepts a 2 V to 25 V rising/falling edge pulse, with a pulse width greater than 500 μ s and converts this into a TTL signal suitable for timed trigger capture with the Rotation Monitor inter-			
Communications and I/O Interface	TCP/IP interface via control computer, one BNC Analog Output (0 - 5 V) labeled "Temp Out" On BandiT rack, one DB15 I/O interface connection on BandiT rack wired for 2 analog Inputs (0 - 10 V) and 1 additional analog output (0 - 5 V), 2 digital inputs and 2 digital outputs (standard TTL levels). Additional analog and digital I/O quoted separately.			

¹ Other mounting configurations available, e.g. for 1.33", 6" and 8" CF viewports, or custom viewports.

kSA BandiT Optical Components and Chamber Requirements

The kSA BandiT mounting configuration varies based on the particular chamber or application. Standard mounting accommodates both 2.75" CF and 4.5" CF flanges. The light source and detector perform best with mounting between zero and 50 degrees from substrate normal and with an angular separation from each other of at least 10 degrees and at most 50 degrees. To confirm the best kSA BandiT configuration for your chamber or application, please contact k-Space for more information.

Standard kSA BandiT Optics

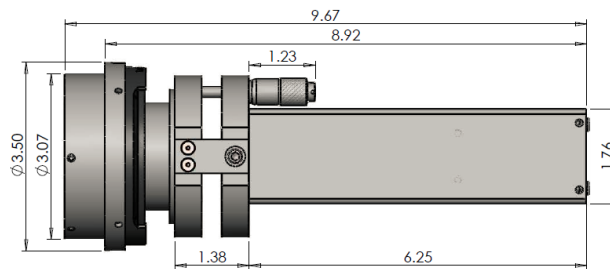

kSA BandiT Detector (B-TRD)

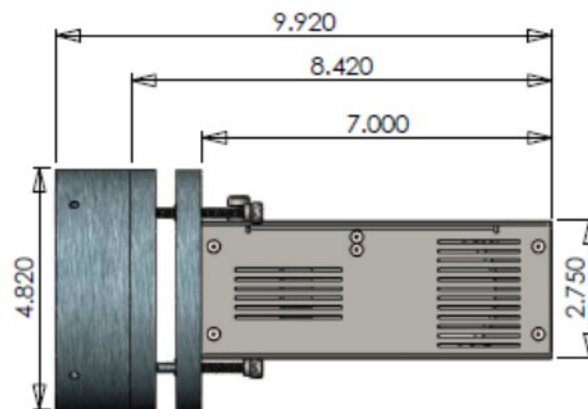

kSA BandiT Light Source (B-LS)



Additional Optics Configurations, Upgrades, or Add-ons:

The standard BandiT optics maybe configured to better suit particular systems or applications. The options listed below are available at the time of BandiT purchase. If a particular upgrade or customization is required and is not listed below, or if you would like to purchase one of these options for an existing BandiT system, please contact k-Space for more information.

Detector/Light Source Add-ons	Description	Schematic
Xenon Light Source <i>kSA-XLS-MBE/U</i>	Replaces standard B-LS with 300 W Xenon light source with controller for high intensity output from 380-750 nm, 1mm core VIS fiber (10m), integrated filter holder (UV filter included), fast-acting electronic shutter, and control via kSA software. Standard 2.75" or 4.5" CF vacuum chamber mounting and focusing optics are included. (Ideal for use with B-VIS-MBE-600 for GaN/SiC temperature monitoring.)	
Single Port Optics <i>B-C-NN/U</i>	Only suitable for use with B-NIR-MBE-1400 or B-NIR-MBE-1670, it replaces the standard BandiT optics with an integrated, single viewport light source and detector. Includes light source and detector optics along with custom beam splitter optics integrated into one optical head for use on a single, non-normal viewport. Must not have an opposing port at specular angle, and requires an angled viewport (quoted separately).	
Detector with Camera <i>B-TRD-C</i>	Upgrades standard BandiT Detector to include an integrated color video camera for simultaneous real-time visual image of the sample and sample temperature. Minimum focal length of 300 mm, long nipples with I.D. of 38 mm (or less) may experience vignetting. Camera communications and power via PoE and is supplied with a PCIe board and a 10 m CAT5E cable. The BandiT software supports camera image acquisition and storage with this upgrade.	
Scanning Detector <i>B-SD/U</i>	Upgrades standard BandiT Detector to a Scanning Detector and Software for full wafer or carrier scanning. Includes fully-automated software control of detector position with servo-motor driven detector and USB servo controller. Full optical access and rotational trigger signal required. Requires a dedicated computer for kSA BandiT operation. Standard servo-motor cable (6 m) connects from detector to the BandiT rack.	

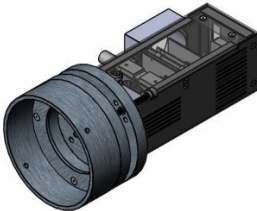
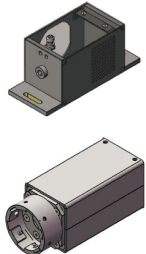
Light Source and Detector Extension Tubes <i>B-TRD-ET or B-LS-ET</i>	For chamber mounting where BandiT optics cannot be connected directly to the chamber viewport. Standard extension tube adds an additional 165 mm of length to the standard optics mounting configuration.	
Light Source with Integral Shutter <i>B-LS-SH/U</i>	Replaces standard BandiT Light Source with BandiT Light Source with an integral shutter. User controls shutter directly via a TTL signal on a BNC cable. Ideal for absorbing substrates that will heat up with excessive light source exposure.	
External Light Source and lens <i>B-LS-EXT/U</i>	Replaces standard BandiT Light Source with external light source and lens mounting for use with back side light pipe configuration for transmission mode BandiT measurements. Custom mounting available upon request. External light source uses a 1 mm core fiber (10 m length) with SMA connectors.	

Additional Spectrometer, Software and Other Add-ons:

The standard BandiT hardware maybe configured to better suit particular systems or applications. The options listed below are available at the time of BandiT purchase. A standard BandiT rack accommodates up to a total of two spectrometers. If a particular upgrade or customization is required and is not listed below, or if you would like to purchase one of these options for an existing BandiT system, please contact k-Space for more information.

Spectrometer Add-ons	Description
NIR-HRC/U	<ul style="list-style-type: none"> Replaces the standard B-NIR-MBE-1670 with a high resolution, cooled NIR spectrometer: 870-1670 nm, 256 element cooled InGaAs array, integration time 10 μs - 20 s. Ideal for optimal band-edge and blackbody temperature resolution at low temperatures or signal levels. Typically provides 20 times increase in signal strength over standard NIR spectrometer.
NIR-2-1670/U¹	<ul style="list-style-type: none"> Adds a standard 870 nm - 1670 nm NIR spectrometer to a BandiT system purchase for additional functionality. Spectrometer: 870-1670 nm, 128 element InGaAs array, Integration Time 10 μs - 5 s.
VIS-2-1100/U¹	<ul style="list-style-type: none"> Adds a 600 nm - 1100 nm VIS spectrometer to a BandiT system purchase for additional functionality. Spectrometer: 600-1100 nm, 512 element Si CCD, cooled, Integration Time 4 ms - 20 s.
VIS-2-600/U¹	<ul style="list-style-type: none"> Adds a 350 nm - 600 nm VIS spectrometer to a BandiT system purchase for additional functionality. Spectrometer: 350-600 nm, 512 element Si CCD, cooled, Integration Time 4 ms - 20 s.

¹May require other accessories (fibers, lens, etc.) depending on end user implementation.



Software Add-ons	
Multi-Wafer Production Software <i>B-MWP</i>	<ul style="list-style-type: none"> Multi-Wafer Production Software provides capability of collecting wafer specific data from user defined markers in real-time. Full optical access and rotational trigger signal required. Requires a dedicated computer for kSA BandiT operation.
Analysis Only Software <i>B-AOS</i>	<ul style="list-style-type: none"> Analysis Only Software provides complete kSA BandiT functionality with the exception of data acquisition. Designed for users who want to perform post-acquisition display, processing, and analysis away from the laboratory. Analysis only sentinel key provided for software operation. (One complementary B-AOS is supplied with new kSA BandiT system purchase.)

Other Add-ons	
Laser-based Rotational Triggering System <i>kSA-TRG</i>	<ul style="list-style-type: none"> Optically-based rotational trigger generator. Provides TTL level output signal based on position of user mounted reflective tape on system's rotational shaft. Includes optical sensor, standard mounting bracket, and cable (10 m) for power and trigger signal output. Custom mounting brackets quoted separately. Must have optical access to the rotation shaft, ideally at a distance of 50 – 600 mm.
kSA Computers	<ul style="list-style-type: none"> <i>kNB-LLT</i>: Laptop Computer <i>kCPU-DT</i>: Mid-Tower Computer (includes mouse, keyboard and 22" monitor) <i>kCPU-A4U</i>: 4U Rack Mount Computer (includes mouse, keyboard and 22" monitor)

Computer Requirements

k-Space highly recommends purchasing a computer from k-Space for optimum use with kSA BandiT data acquisition and analysis software. Computers purchased from k-Space have all software, drivers, suggested settings, and required files pre-installed for fast and easy system set-up. Please refer to the kSA Computer Product Specifications for details. If another computer is used it must meet the following minimum specifications:

Operating System: Windows™ 10

Processor: Dual Core Processor (I3 or better),

RAM: Minimum 4 GB

Hard Drive: Minimum 250 GB

Video: 1024 x 768, 16-bit depth or better

Interface: USB 2.0 port or higher

kSA BandiT Integrated Software

kSA BandiT data acquisition and analysis software is a full featured package that controls and monitors the light source, spectrometer(s), and all data I/O, as described below. Hardware interface is through a single USB connection to the BandiT rack. The customizable user interface offers real-time display of temperature, thickness, surface roughness, growth rate, processed spectra and curve fitting routines. In addition to I features are following:

- Complementary analysis only software license for post-deposition/acquisition analysis. Data storage in ASCII, Excel, or binary file formats facilitates alternative data analysis by user.
- Copies graphics directly to Windows clipboard or exports directly to .wmf, .bmp, .png, or .tif formats. Export data to .xls and .txt formats.
- TCP/IP interface for custom, real-time data transfer and program control.
- Ability to write data in real-time to an SQL database.
- Analog and digital data I/O capability.
- User-configurable window layout.

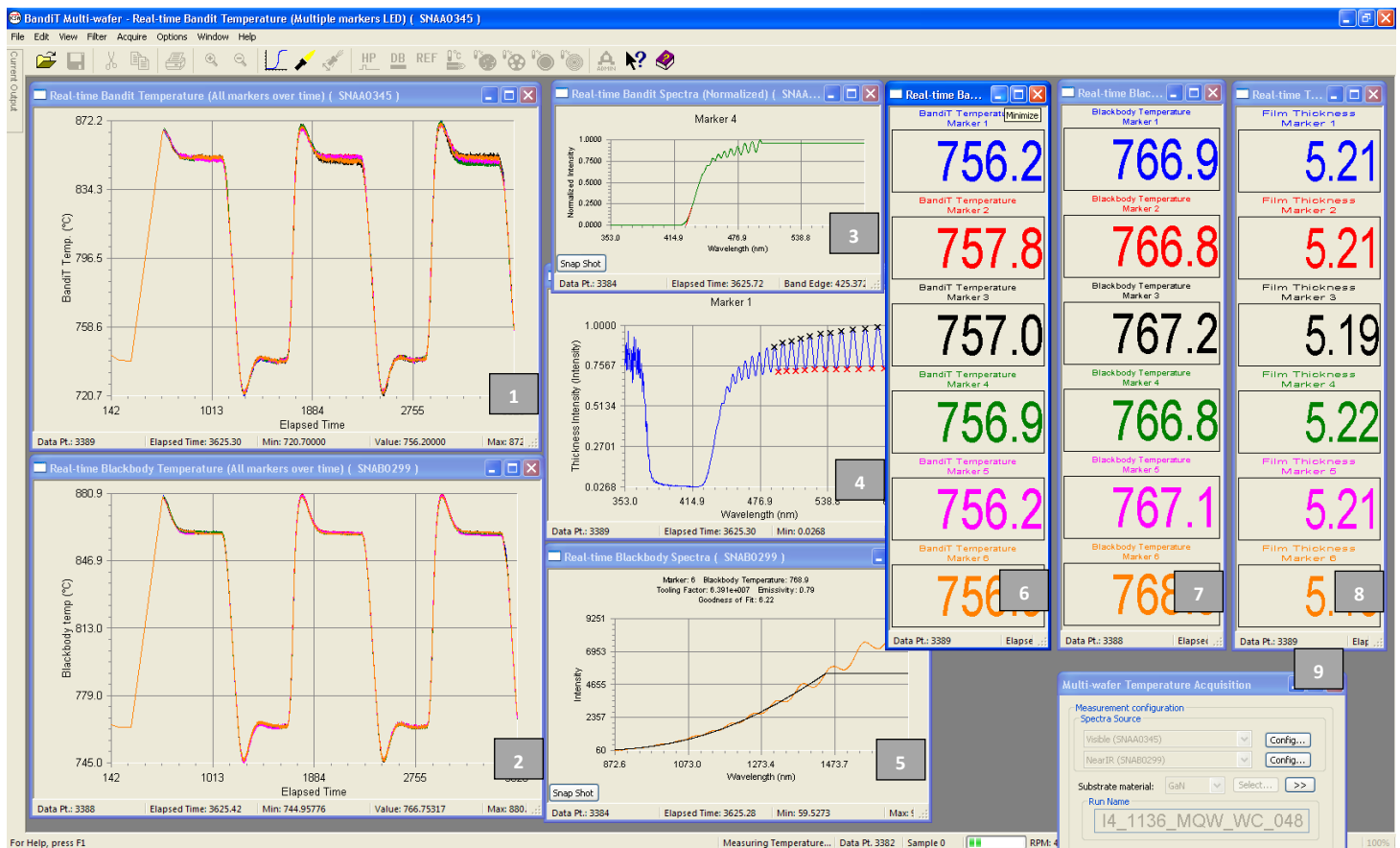

1	BandiT (band edge) Temperature vs. time for each marker
2	Blackbody Temperature vs. time for each marker
3	Real-time BandiT Spectra from VIS spectrometer (350 nm - 600 nm) with band edge fitting.
4	Real-time layer thickness fitting from VIS spectrometer (350 nm - 600 nm) with peak locations.
5	Real-time Blackbody Spectra from NIR spectrometer (870 nm - 1670 nm) with blackbody curve fitting.
6	Latest BandiT temperature values measured for each marker position
7	Latest Blackbody temperature values measured for each marker position
8	Latest layer thickness values measured for each marker position
9	Multi-wafer Temperature Acquisition window

kSA BandiT software screen shot of multiple real-time multi-wafer measurements for GaN grown on GaN/Sapphire templates

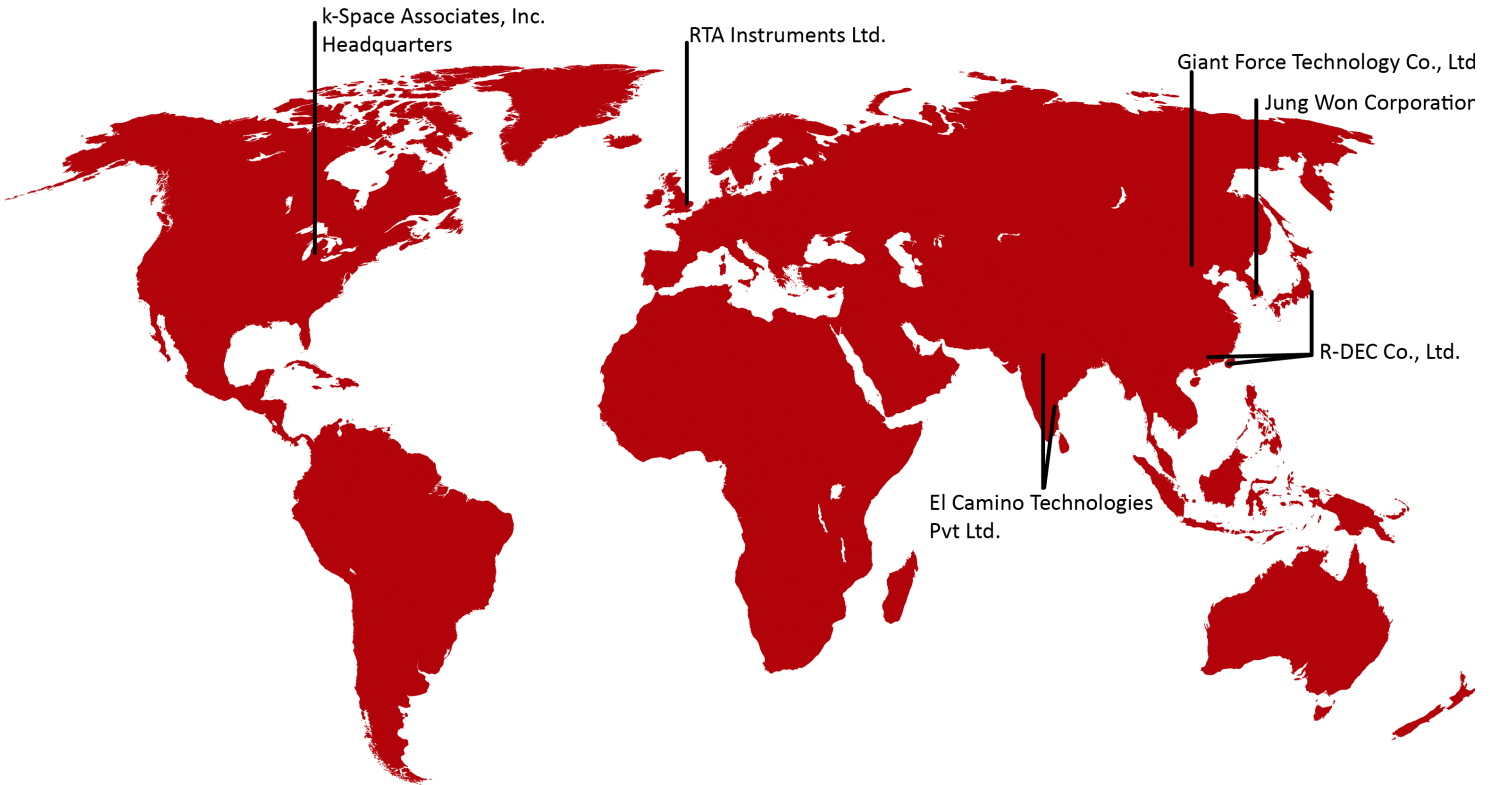

k-Space has an expansive network of distributors to best serve our worldwide customer base.

HEADQUARTERS

k-Space Associates, Inc.
Michigan, USA
www.k-space.com
requestinfo@k-space.com

El Camino Technologies Pvt Ltd.
India
www.elcamino.in
chetnamohan@gmail.com

Jung Won Corporation
South Korea
www.jwc.co.kr
salesinfo@jwc.co.kr

DISTRIBUTION PARTNERS

RTA Instruments Ltd.
Europe
www.rta-instruments.com
info@rta-instruments.com

Giant Force Technology Co., Ltd.
China
www.giantforce.cn
giantforce@gmail.com

R-DEC Co., Ltd.
Japan
Hong Kong
Taiwan
www.rdec.co.jp
info@rdec.co.jp

Specifications are subject to change without notice. While due caution has been exercised in the production of this document, possible errors and omissions may occur.

kSA BandiT Product Specifications 23JUL20